

Needle Roller Bearing Installation Guide

Koyo®

Ball, Needle & Roller Bearings



Installation Procedures for Drawn Cup Needle Roller Bearings

Drawn cup needle bearings provide high load-carrying capacity with minimum required space.

While easily installed with a press fit in the housing, proper installation tool and procedures are recommended for a successful application.

Highlighted below are general guidelines that apply when installing a drawn cup needle roller bearing.

- *A drawn cup bearing must be pressed into its housing.*
- *An installation tool must be used in conjunction with a standard press.*

The installation tool should:

1. Have a back angle, around 15 degrees, on the shoulder used to apply the press force to the bearing outer ring.
2. Have a pilot to center and guide the bearing.
3. Have a ball detent on the pilot if the bearing being installed is a full complement type.
4. Be on the same axis as the housing bore.
5. Be made to specific dimensions, based on the equipment manufacturer's recommendations.

6. Press against the stamped end of the bearing (typically thicker).
7. The bearing must not be hammered into its housing even if a proper installation tool is being used.
8. The bearing should not be pressed tightly against a shoulder in the housing. If it is necessary to use a shouldered housing, the depth of the housing bore must be sufficient to ensure that the housing shoulder fillet and shoulder face clear the bearing.

If these guidelines are not followed the bearing may be damaged during installation.

Fig. 1

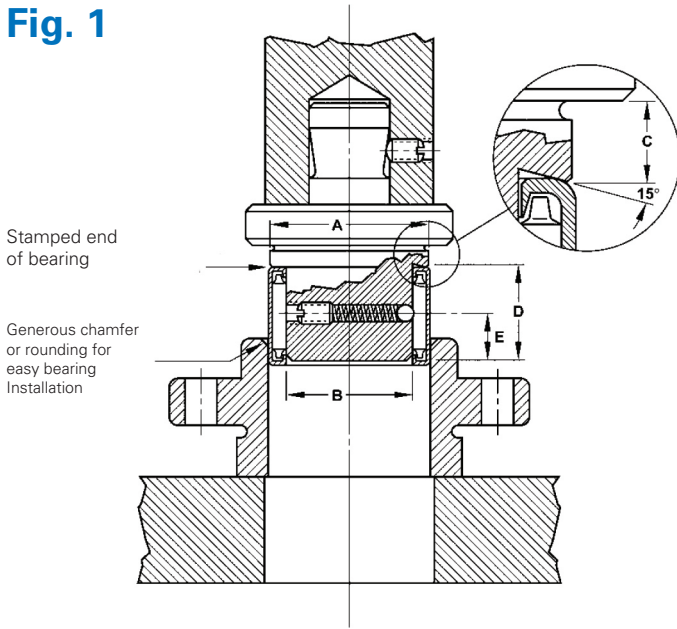

- A – 1/64" less than housing bore
- B – 0.003" less than shaft diameter
- C – distance bearing will be inset into housing, minimum of 0.008"
- D – pilot length should be length of bearing less 1/32"
- E – approximately 1/2 D

Installation of Open-End Bearings

To install an open-end bearing, use a positive stop on the press tool to properly locate the bearing in the housing. The installation tool should also have a pilot to aid in making the bearing true in the housing from the start. The ball detent shown in Fig. 1 assists in aligning the rollers of a full complement bearing during installation. It also assists in holding the bearing on the installation tool. A caged-type drawn cup bearing does not require a ball detent to align its rollers, although the ball detent may still be used to hold the bearing on the installation tool. An O-ring also may be used for this purpose. The bearing should be installed with the stamped end – the end with identification markings – against the angled shoulder of the pressing tool.

Fig. 2

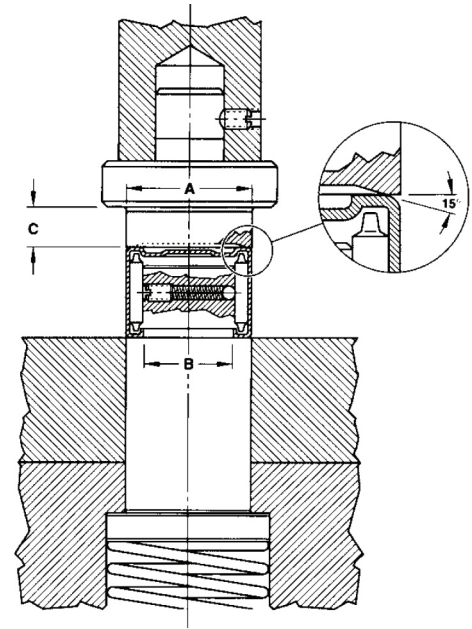

- A – 1/64" less than housing bore
- B – 0.003" less than shaft diameter
- C – distance bearing will be inset into housing, minimum of 0.008"

Installation of Closed-End Bearings

To install a closed-end bearing, a slightly different tool is required. The installation tool combines all the features of the tool used to install open-end bearings, but the pilot is spring loaded and is part of the press bed. The angled shoulder of the pressing tool should bear against the closed end, with the bearing held on the pilot to aid in starting the bearing true in the housing (Fig. 2).



Call Koyo Today 1-800-331-5696

Our sales and service engineers are available to assist with product design needs, maintenance recommendations, and technical support.

To learn more, contact your sales representative or visit us online at:

www.JTEKT-NA.com

Koyo is a registered trademark of JTEKT Corporation



WARNING !

Failure to observe the following warning could create a risk of serious injury.

Proper maintenance and handling procedures are critical. Always follow installation instructions and maintain proper lubrication.