

Koyo®

Engine Components & Subsystems

**B
E
A
R
I
N
G
SOLUTIONS**

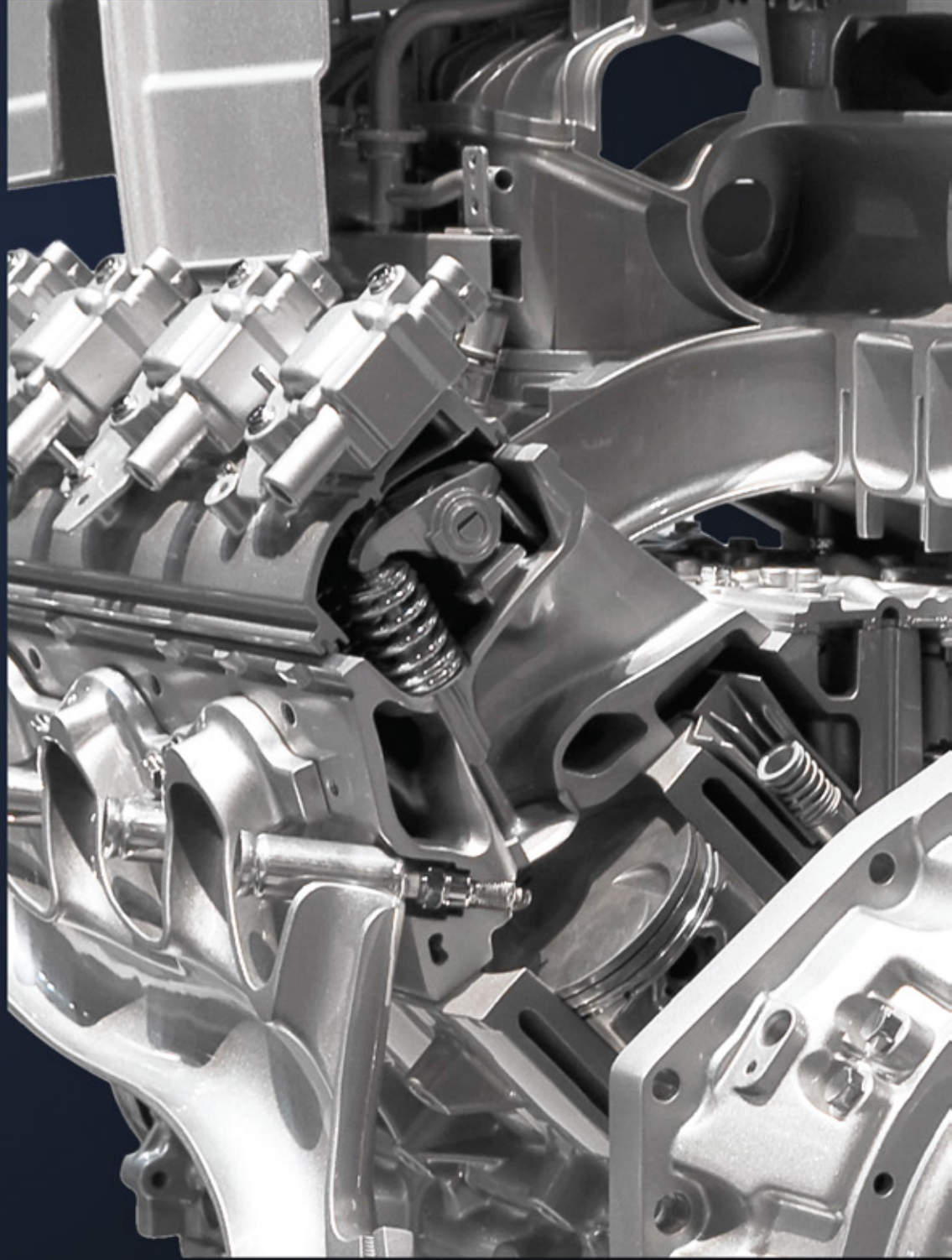

JTEKT

Koyo | **TOYODA**

Koyo Bearings ... Preferred choice



Balance Shaft Components



Valve Train Components

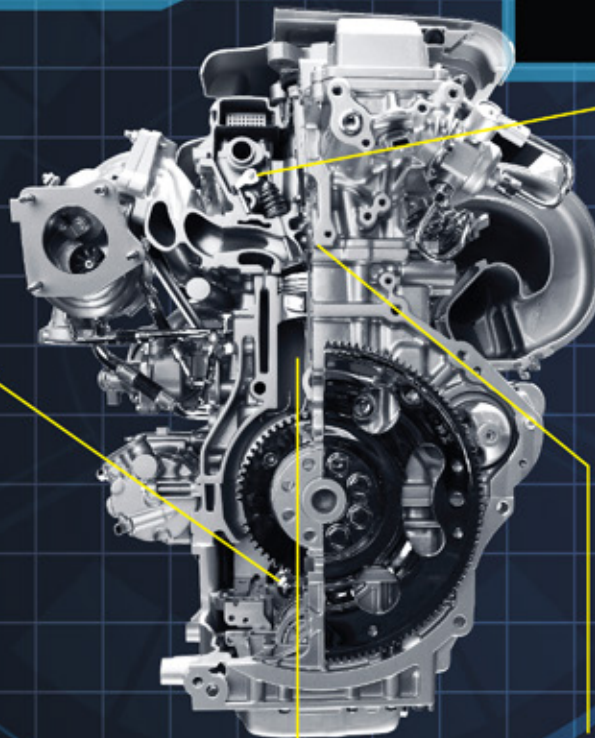

Piston & Crank Components



Accessory Components

Koyo Value Proposition

-  Experienced Global OEM Bearing & Engine Component Manufacturer
-  ISO & IATF 16949 Certified
-  Product Design & Development At The Systems Level
-  Designs That Lead To Improvements In Efficiency & Durability
-  Complete Global Test & Metallurgical Support
-  Innovation & Customer Value Add-In Design Solutions
-  Integrated Bearing Technology & Manufacturing (KOYO Ball, Needle & Roller)
-  Global Manufacturing Footprint

Using tomorrow's technology today

Koyo has been producing innovative bearings and component solutions for the automotive industry for more than 70 years, and today our products can be found in automotive engine applications around the globe. OEMs trust Koyo to meet or exceed the capacity, life, and environmental demands of today's competitive automotive industry.

Koyo approaches internal engine component and drive train design and development at the systems level.

On and off the road, Koyo's engine components and systems provide superior quality and performance world wide.



Koyo's knowledge and experience in developing valve train components yields products that optimize mass, stiffness and moment of inertia.

These design features meet the demanding increases in engine operating speeds, improved fuel economy, and better performance.



Koyo also offers unique anti-friction solutions for camshaft and balancer shaft applications. These solutions provide significant friction reduction, especially at low engine speeds and cold start conditions, resulting in significant reductions in CO2 emissions.



JTEKT Proving Grounds located in Japan and France

JTEKT Iga Proving Ground (Iga City, Japan shown)

Site Area:	500,000 m ²
Course Area:	170,000 m ²
Combined Circuit Length:	2,200 m
Dynamics Pad Area:	54,000 m ²



Further friction reduction in engines

Koyo researchers, in concert with the EPA, continue to work on advanced friction reducing technologies that will lead to even greater improvements in engine performance, durability, and efficiency. The application of roller element bearings to engines reduces start-up torque and improves durability in start-stop applications. Reduced oil requirements are an additional benefit of our friction reducing bearing designs which can result in oil pump downsizing.

Fuel Consumption Results

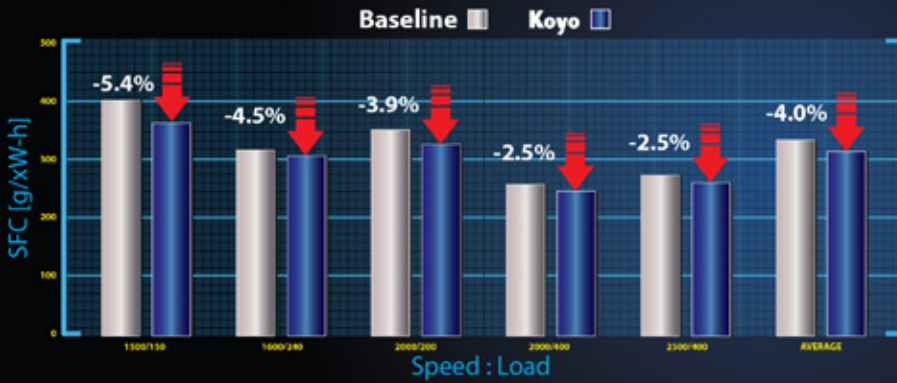

Motoring Torque Improvement

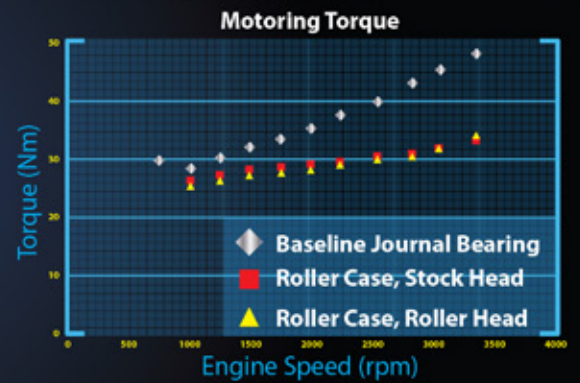

These graphs illustrate improvements achieved by Koyo during development and initial testing in various applications. Please contact your Koyo application engineer to discuss your specific project.

Working with another Tier 1 supplier, Koyo has developed and validated the world class leading solution for the application of needle roller bearings to camshafts. Koyo is also experienced in the development and production of bearings for the challenging high speed balance shaft environment. Koyo is leading the way bringing new technologies to the market that will decrease emissions while increasing fuel efficiency and performance.



Koyo Strategic Product Development Process



Friction reduction is our specialty

Today's engine designers are faced with the need for improved fuel economy and durability while meeting strict emissions regulations and tight cost constraints. Koyo excels at providing practical solutions to engine design problems by developing innovative ways to improve efficiency in these demanding applications.



When the capabilities of stamped finger followers were exceeded in some applications, Koyo's innovative response was to develop the Formed Finger Follower which features friction reducing lower effective mass, higher stiffness, and lower operating stresses. This product enables increased fuel efficiency by allowing more aggressive valve events with unparalleled reliability. It is the choice of engine designers requiring exacting, economical performance standards.

Koyo engineers helped engine designers solve the challenge of improving the fuel economy and emissions in pushrod engines. The solution needed to be durable and efficient without drastically modifying the engine architecture. Koyo's engineers developed an innovative unitized roller rocker arm assembly allowing engine designers to maximize performance, reduce emissions, simplify assembly, and reducing valve train system noise.



Through research and innovation, Koyo continues to solve problems with revolutionary designs that take automotive components to the next level of performance, quality, efficiency and durability.

Koyo®

Finger Follower Comparison Study

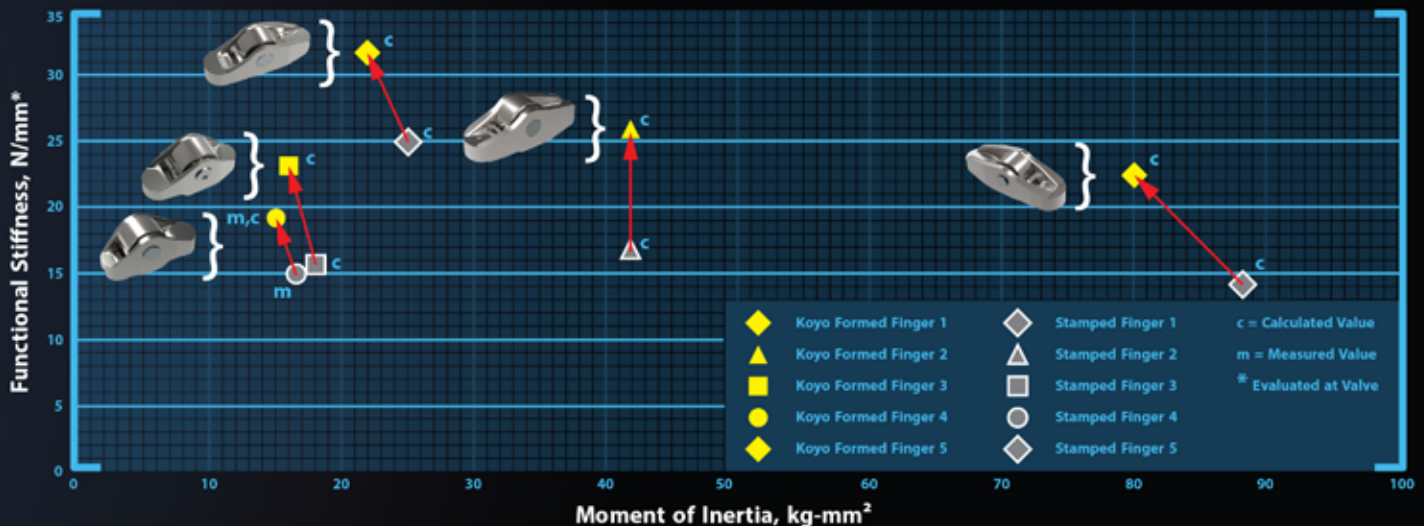

NOTE: Improved performance indicated by arrows UP and to the LEFT

Koyo is so much more than bearings

In fact our goal is to go even further by offering services, training and engineering support that far exceeds our customers' expectations through global technical support.

JTEKT Corporation was established in January 2006 through the merger of Koyo Seiko Co., Ltd., a world-class bearing manufacturer founded in 1921, and Toyoda Machine Works, Ltd., a leading machine tool manufacturer excelling in cutting-edge machining technologies that was founded in 1941. Combining the most advanced technologies and the manufacturing expertise of both companies, JTEKT delivers innovative products that satisfy the most demanding customers all over the world.

The JTEKT idea of "monozukuri", Japanese for craftsmanship, carefully considers such issues as what products are needed in the marketplace, how and where to make them, and how they should be provided to our customers.

JTEKT makes parts, components, and systems for just about every industry: from bearings, drive-line components, gears, pumps, and steering systems, to high-tech, ultra-precise milling machines and the mechatronic controls that keep them all moving.

JTEKT Corporation and its 136 consolidated subsidiaries employ over 44,000 people world-wide, with JTEKT North America boasting 15 of JTEKT's 65 global manufacturing plants and over 7,000 employees across plants, tech centers, warehouses, and operations.

As a leading automotive supplier, JTEKT consistently ranks in the top 20 (out of 100) globally*



Greenville, SC Technology Center



Plymouth, MI Technology Center

JTEKT North America operates two Technology Centers. One is located in Plymouth (Detroit), Michigan, and the second is on the CU-ICAR automotive research campus of Clemson University in Greenville, South Carolina. JTEKT boasts 13 such Technology Centers world-wide, supporting our global "Customer First" commitment to quality, reliability, and innovation in motion.

Durability testing methods vary by product or application, so Koyo maintains complete laboratories filled with the latest equipment to meet the most stringent requirements.

*"Top Suppliers", Automotive News supplement, June 2016 (JTEKT ranked number 15 for 2015)

Koyo



Koyo Bearings North America
Email: engineering.inquiries@jtekt.com

www.JTEKT-NA.com